

# Acoustic performance Layers



**Axolight**

# From noise to acoustic comfort, how to do it?

**Noise** is commonly identified as an unwanted and disturbing sound, for example buzzing (an incomprehensible and continuous hum) from a moving car, a drill, etc.

**Acoustic comfort** is the psychophysical condition of wellbeing a person finds themselves in when they are in an environment where noise is limited.

The measurement of **Reverberation Time (RT60)**, or the time required for sound to become imperceptible, allows the acoustic comfort to be measured in any given environment: the higher the reverberation time, the greater the perception of sound.

A setting with reflective materials (such as marble, cement, glass etc) and/or irregular geometric shapes will have high Reverberation Time and therefore tend to be noisy.



# How can the efficiency of an object's sound absorbency be measured?

By measuring the Reverberation Time (RT60) of an enclosed environment both with and without sound-absorbing objects, then taking into account the difference, it is possible to calculate their efficiency.

In order to calculate the Reverberation Time (RT60), the Volume of the enclosed space (V) and the cumulative **Equivalent Sound Absorbing Area (A)** of all the surfaces and objects present in the environment must be known:

$$RT60 = 0,161 \times (V/A)$$

The Equivalent Sound Absorbing Area (A) of each single object (i.e. lamp) takes into account the overall sound-absorbing properties of the materials the object is made of, as well as its size and shape.



To identify the sound-absorbing properties of a single material (not the object in its entirety) it is possible to use the **Sound Absorption Coefficient (α)** whose value can vary from 0, where all incident sound is reflected, to 1, where all incident sound is absorbed. Therefore, if the value of α equals 0,5, 50% of the incident sound on the material's surface is absorbed.

# Layers

Vanessa Vivian

from 2,30

to 5,78

Equivalent Sound Absorbing Area (A)

from -10,8%

to -47,1%

Reduction of noise

Average 500÷2.000 Hz

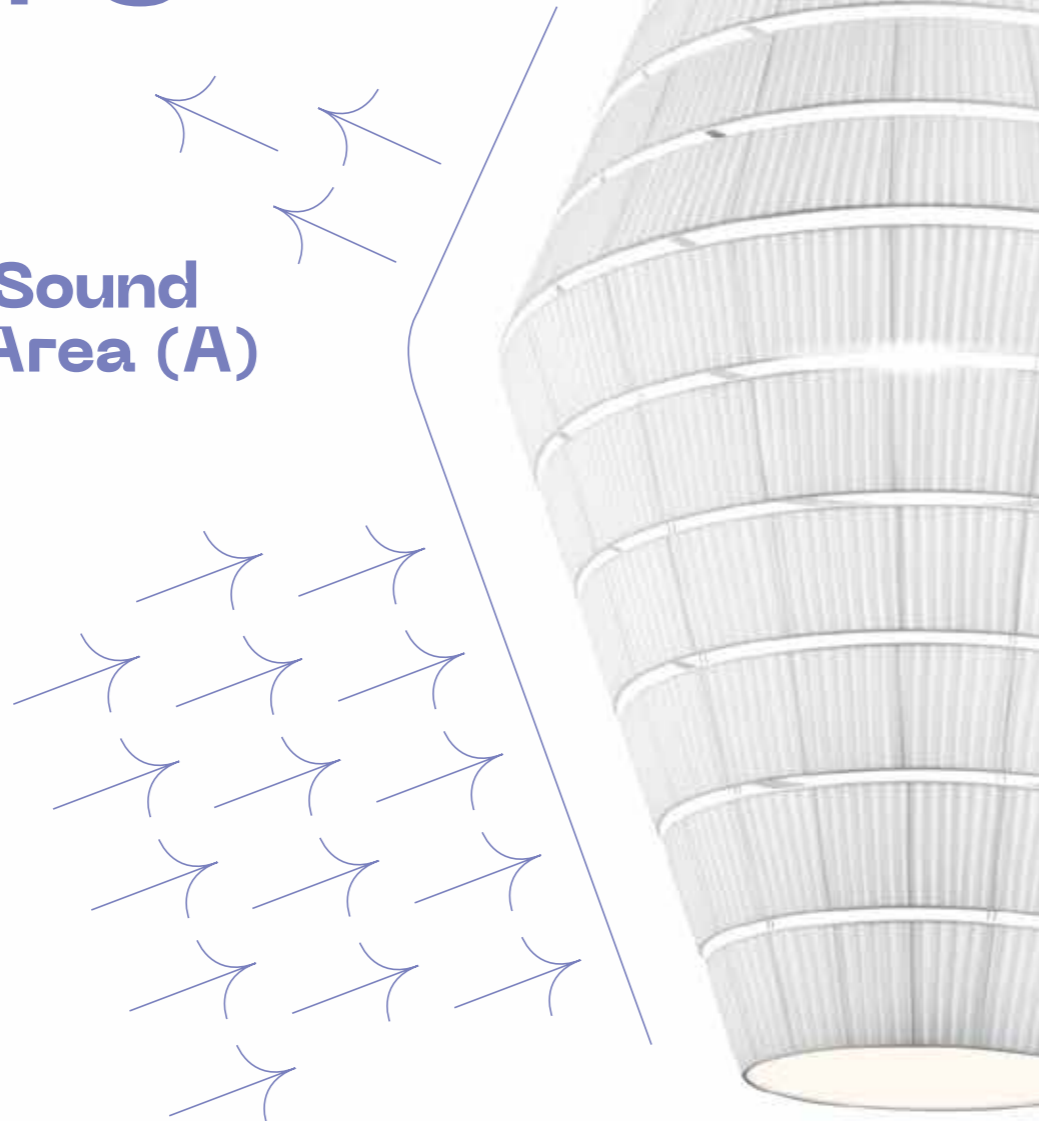

## Index

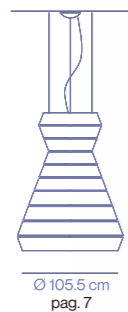

Ø 105.5 cm  
pag. 7

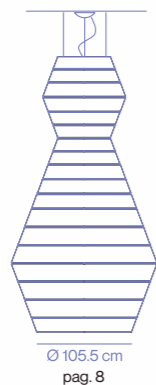

Ø 105.5 cm  
pag. 8

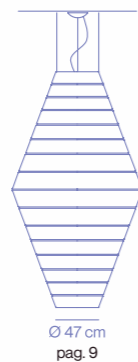

Ø 47 cm  
pag. 9

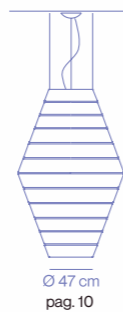

Ø 47 cm  
pag. 10

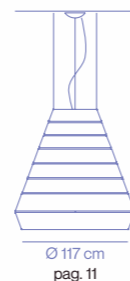

Ø 117 cm  
pag. 11

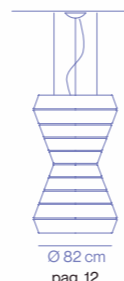

Ø 82 cm  
pag. 12

## Where we tested our products?

The environment used to measure the sound-absorbing properties the Axolight lamps is shown below:

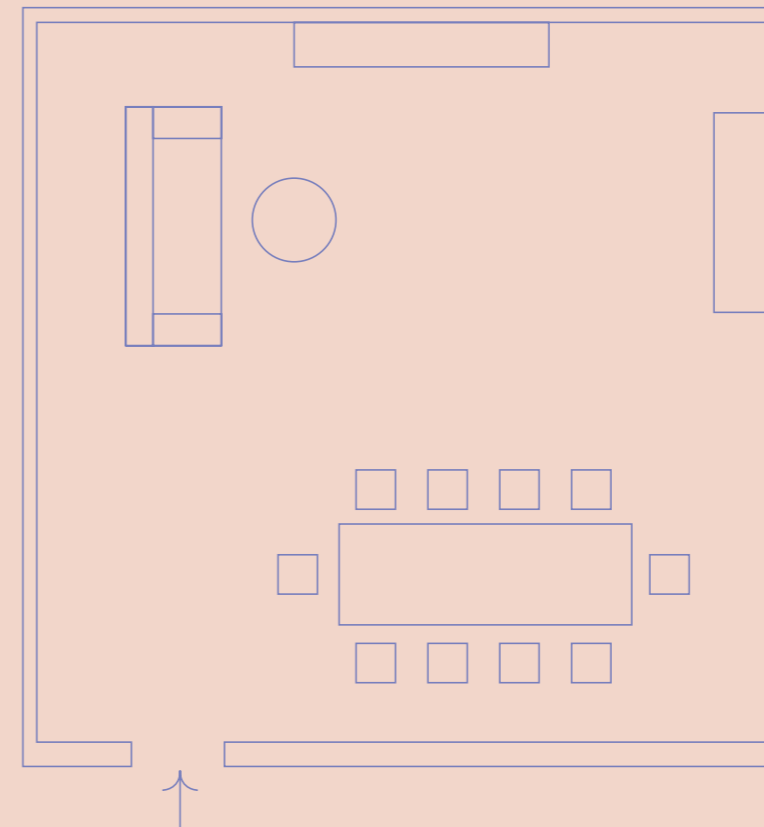

## Room data

$L \rightarrow 7$  m

$w \rightarrow 7$  m

$H \rightarrow 6,1$  m

$\rightarrow 300$  m<sup>3</sup>

The Reverberation Times of the room, with sounds of varying frequencies emitted from an audio source, were measured, first without acoustic lamps, then with 1, 2 or 3 lamps added at a time.

This is how the reduction of sound in the room was calculated.



# SPLAYA

Lighting performance per lamp

144 W / 17289 lm → per lamp

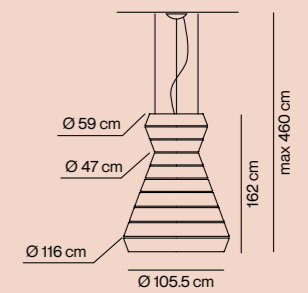

## Acoustic performance

### Before

Initial Reverberation Time (RT60) in s

	LOW		MEDIUM			HIGH		AVERAGE	
FREQUENCY	125 HZ	250 HZ	500 HZ	1000 HZ	2000 HZ	4000 HZ	8000 HZ	125-8000 HZ	500-2000 HZ
RT60	1,64	1,99	<b>2,49</b>	<b>2,68</b>	<b>2,47</b>	2,21	1,60	1,17	1,38

### After

Reduction of Reverberation Time (RT60) in %

1 lamp	<b>-12,2%</b>								
	-1,1%	-7,3%	<b>-9,4%</b>	<b>-13,0%</b>	<b>-14,3%</b>	-14,4%	-13,2%	-10,4%	-12,2%
2 lamps	<b>-21,7%</b>								
	-2,1%	-13,6%	<b>-17,1%</b>	<b>-23,0%</b>	<b>-25,0%</b>	-25,2%	-23,3%	-18,5%	-21,7%
3 lamps	<b>-29,3%</b>								
	-3,2%	-19,1%	<b>-23,6%</b>	<b>-30,9%</b>	<b>-33,4%</b>	-33,6%	-31,3%	-25,0%	-29,3%

Equivalent Sound Absorption Area (A) in m<sup>2</sup> per lamp

FREQUENCY	125 HZ	250 HZ	500 HZ	1000 HZ	2000 HZ	4000 HZ	8000 HZ	125-8000 HZ	500-2000 HZ
A	0,32	1,89	<b>1,99</b>	<b>2,67</b>	<b>3,25</b>	3,66	4,54	2,62	2,64

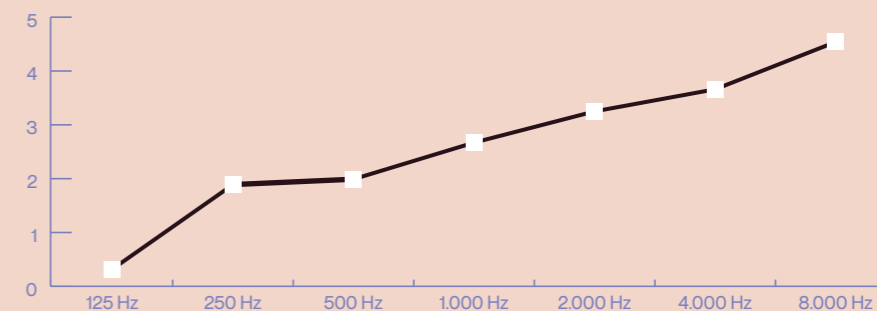

# SPLAYB

Lighting performance per lamp

240 W / 28815 lm → per lamp

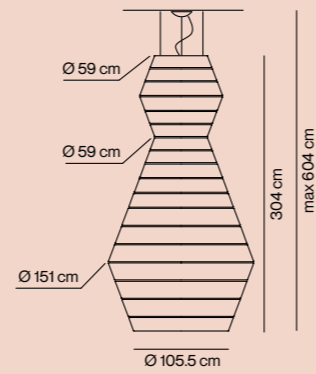

## Acoustic performance

### Before

Initial Reverberation Time (RT60) in s

FREQUENCY	LOW		MEDIUM			HIGH		AVERAGE	
	125 HZ	250 HZ	500 HZ	1000 HZ	2000 HZ	4000 HZ	8000 HZ	125-8000 HZ	500-2000 HZ
RT60	1,64	1,99	2,49	2,68	2,47	2,21	1,60	1,17	1,38

### After

Reduction of Reverberation Time (RT60) in %

1 lamp	-23,2%	-1,1%	-8,8%	-17,6%	-23,7%	-28,2%	-30,5%	-27,3%	-19,6%	-23,2%
2 lamps	-37,4%	-2,2%	-16,2%	-29,9%	-38,3%	-44,0%	-46,8%	-42,9%	-31,5%	-37,4%
3 lamps	-47,1%	-3,3%	-22,5%	-39,1%	-48,2%	-54,1%	-56,9%	-52,9%	-39,6%	-47,1%

Equivalent Sound Absorption Area (A) in m<sup>2</sup> per lamp

FREQUENCY	125 HZ	250 HZ	500 HZ	1000 HZ	2000 HZ	4000 HZ	8000 HZ	125-8000 HZ	500-2000 HZ
A	0,33	2,33	4,12	5,56	7,65	9,54	11,22	5,82	5,78

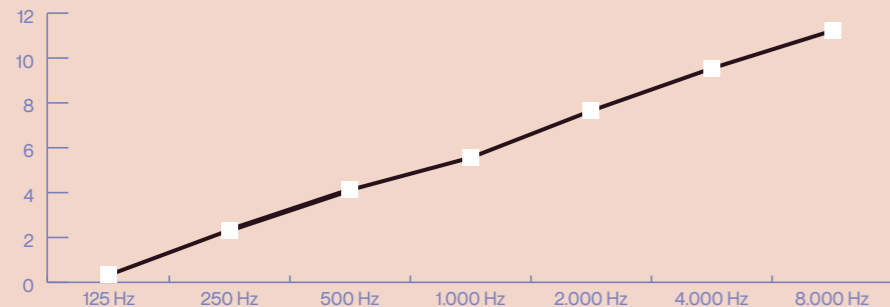

# SPLAYC

Lighting performance per lamp

240 W / 28815 lm → per lamp

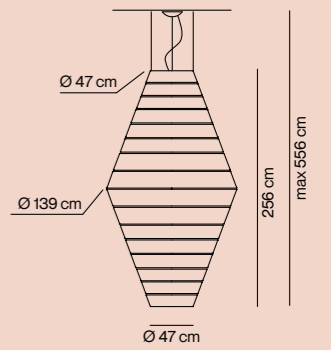

## Acoustic performance

### Before

Initial Reverberation Time (RT60) in s

FREQUENCY	LOW		MEDIUM			HIGH		AVERAGE	
	125 HZ	250 HZ	500 HZ	1000 HZ	2000 HZ	4000 HZ	8000 HZ	125-8000 HZ	500-2000 HZ
RT60	1,64	1,99	2,49	2,68	2,47	2,21	1,60	1,17	1,38

### After

Reduction of Reverberation Time (RT60) in %

1 lamp	-17,6%	-1,1%	-8,5%	-14,3%	-17,8%	-20,8%	-22,4%	-20,4%	-15,0%	-17,6%
2 lamps	-29,9%	-2,2%	-15,6%	-25,1%	-30,2%	-34,5%	-36,7%	-33,8%	-25,4%	-29,9%
3 lamps	-39,0%	-3,3%	-21,7%	-33,4%	-39,3%	-44,1%	-46,5%	-43,4%	-33,1%	-39,0%

Equivalent Sound Absorption Area (A) in m<sup>2</sup> per lamp

FREQUENCY	125 HZ	250 HZ	500 HZ	1000 HZ	2000 HZ	4000 HZ	8000 HZ	125-8000 HZ	500-2000 HZ
A	0,33	2,23	3,23	3,87	5,12	6,28	7,65	4,10	4,07

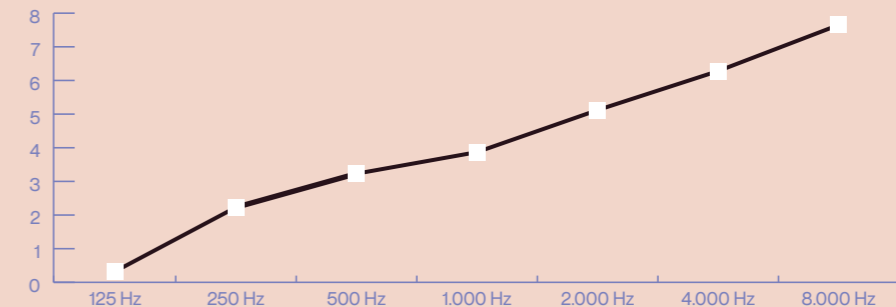

# SPLAYD

Lighting performance per lamp

144 W / 17289 lm → per lamp

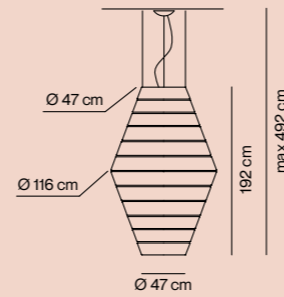

## Acoustic performance

### Before

Initial Reverberation Time (RT60) in s

FREQUENCY	LOW		MEDIUM			HIGH		AVERAGE	
	125 HZ	250 HZ	500 HZ	1000 HZ	2000 HZ	4000 HZ	8000 HZ	125-8000 HZ	500-2000 HZ
RT60	1,64	1,99	<b>2,49</b>	<b>2,68</b>	<b>2,47</b>	2,21	1,60	1,17	1,38

### After

Reduction of Reverberation Time (RT60) in %

1 lamp	<b>-13,5%</b>									
	-1,1%	-7,7%	<b>-11,7%</b>	<b>-13,8%</b>	<b>-15,1%</b>	-16,0%	-14,9%	-11,5%	-13,5%	
2 lamps	<b>-23,8%</b>									
	-2,2%	-14,3%	<b>-21,0%</b>	<b>-24,3%</b>	<b>-26,2%</b>	-27,6%	-26,0%	-20,2%	-23,8%	
3 lamps	<b>-31,9%</b>									
	-3,3%	-20,0%	<b>-28,5%</b>	<b>-32,5%</b>	<b>-34,7%</b>	-36,4%	-34,5%	-27,1%	-31,9%	

Equivalent Sound Absorption Area (A) in m<sup>2</sup> per lamp

FREQUENCY	125 HZ	250 HZ	500 HZ	1000 HZ	2000 HZ	4000 HZ	8000 HZ	125-8000 HZ	500-2000 HZ
A	0,33	2,01	<b>2,56</b>	<b>2,87</b>	<b>3,45</b>	4,14	5,25	2,94	2,96

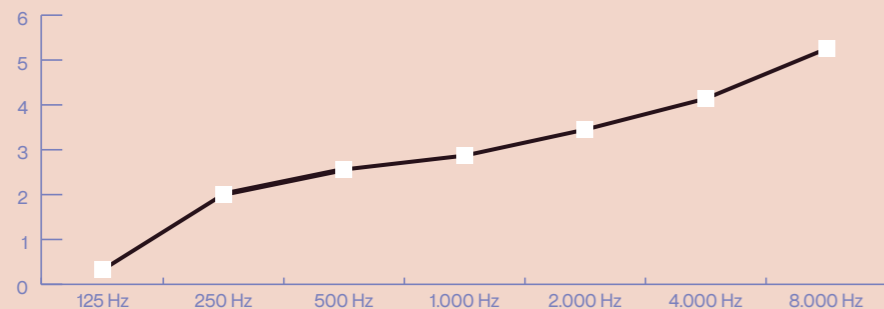

# SPLAYE

Lighting performance per lamp

144 W / 17289 lm → per lamp

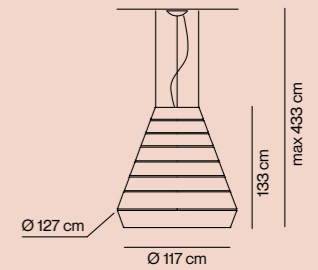

## Acoustic performance

### Before

Initial Reverberation Time (RT60) in s

FREQUENCY	LOW		MEDIUM			HIGH		AVERAGE	
	125 HZ	250 HZ	500 HZ	1000 HZ	2000 HZ	4000 HZ	8000 HZ	125-8000 HZ	500-2000 HZ
RT60	1,64	1,99	<b>2,49</b>	<b>2,68</b>	<b>2,47</b>	2,21	1,60	1,17	1,38

### After

Reduction of Reverberation Time (RT60) in %

1 lamp	<b>-12,9%</b>									
	-1,2%	-7,3%	<b>-11,2%</b>	<b>-13,8%</b>	<b>-13,7%</b>	-13,6%	-12,4%	-10,5%	-12,9%	
2 lamps	<b>-22,9%</b>									
	-2,3%	-13,6%	<b>-20,2%</b>	<b>-24,3%</b>	<b>-24,2%</b>	-23,9%	-22,0%	-18,6%	-22,9%	
3 lamps	<b>-30,8%</b>									
	-3,4%	-19,1%	<b>-27,5%</b>	<b>-32,5%</b>	<b>-32,3%</b>	-32,0%	-29,8%	-25,2%	-30,8%	

Equivalent Sound Absorption Area (A) in m<sup>2</sup> per lamp

FREQUENCY	125 HZ	250 HZ	500 HZ	1000 HZ	2000 HZ	4000 HZ	8000 HZ	125-8000 HZ	500-2000 HZ
A	0,34	1,89	<b>2,44</b>	<b>2,87</b>	<b>3,10</b>	3,41	4,23	2,61	2,80

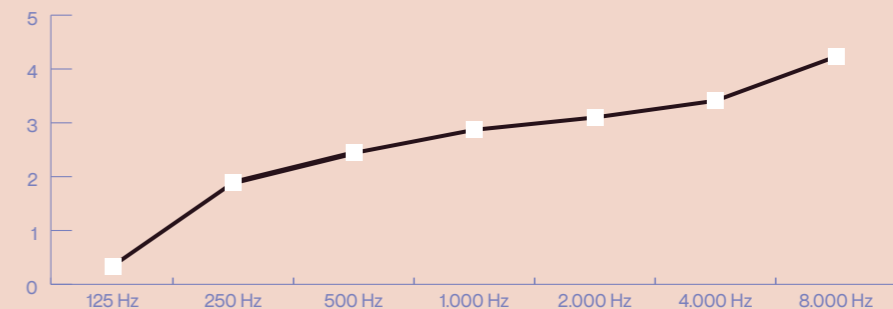

# SPLAYF

Lighting performance per lamp

144 W / 17289 lm → per lamp

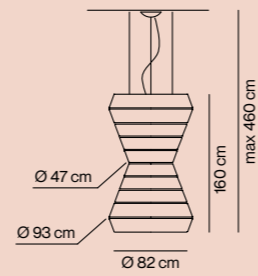

## Acoustic performance

### Before

Initial Reverberation Time (RT60) in s

	LOW		MEDIUM			HIGH		AVERAGE	
FREQUENCY	125 HZ	250 HZ	500 HZ	1000 HZ	2000 HZ	4000 HZ	8000 HZ	125-8000 HZ	500-2000 HZ
RT60	1,64	1,99	2,49	2,68	2,47	2,21	1,60	1,17	1,38

### After

Reduction of Reverberation Time (RT60) in %

1 lamp <b>-10,8%</b>	-1,1%	-6,4%	<b>-9,1%</b>	<b>-11,0%</b>	<b>-12,4%</b>	-14,4%	-13,2%	-9,7%	-10,8%
2 lamps <b>-19,5%</b>	-2,1%	-12,1%	<b>-16,7%</b>	<b>-19,9%</b>	<b>-22,0%</b>	-25,2%	-23,4%	-17,3%	-19,5%
3 lamps <b>-26,7%</b>	-3,1%	-17,1%	<b>-23,2%</b>	<b>-27,1%</b>	<b>-29,8%</b>	-33,6%	-31,4%	-23,6%	-26,7%

Equivalent Sound Absorption Area (A) in m² per lamp

FREQUENCY	125 HZ	250 HZ	500 HZ	1000 HZ	2000 HZ	4000 HZ	8000 HZ	125-8000 HZ	500-2000 HZ
A	0,31	1,66	<b>1,94</b>	<b>2,22</b>	<b>2,75</b>	3,66	4,56	2,44	2,30

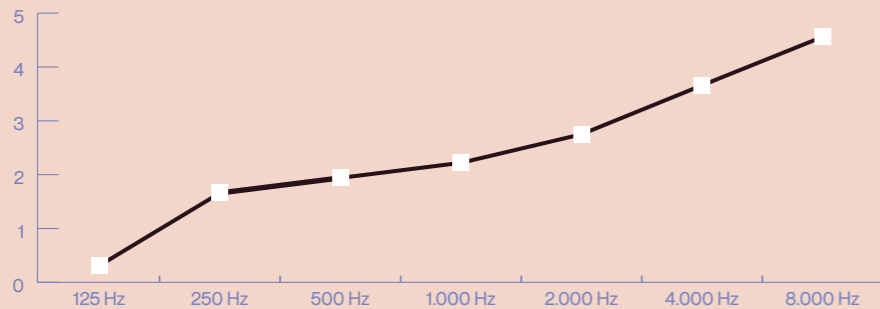

# Note

---

---

---

---

---

---

---

---

---

---

---

---

---

---

---

---

---

---

---

---

---

---

---

---