



EGLO



CUSTOMIZED MULTI PENDANTS
LUMINAIRES SUSPENDUS PERSONNALISÉS

CUSTOMIZED MULTI PENDANTS

LUMINAIRES SUSPENDUS PERSONNALISÉS



Our products comply with C-UL-US & cETLus standards.
Nos produits sont conformes aux normes C-UL-US et cETLus.

Errors, misprints, model and price changes are without reservation.
Photos and drawings may not always represent the product accurately.

Actual product may not be exactly as shown due to adaptation for
the North American market.

Les erreurs, fautes typographiques, changements de modèles
et de prix sont sans réserve. Les photos et les dessins peuvent ne pas
toujours représenter exactement le produit.

Le produit réel peut différer de l'illustration en raison de l'adaptation pour le marché Nord-
Américain.



BRING YOUR VISION TO LIGHT

Create original designs and match your favorite pendants with our new canopies.

Round, square or rectangular shapes, our new canopies as well as our large selection of suspended lights will give life to your rooms and help you to realize your creative projects.

ILLUMINEZ VOS HORIZON

Créez des design originaux et assortissez vos luminaires favoris à l'aide de nos nouveaux canopées.

De formes rondes, carrés ou rectangulaires, les canopées ainsi que notre grande sélection de luminaires suspendus vont donner vie à vos pièces et vous aidez à réaliser vos projets de créations.



1 Choose your canopy Choisissez votre canopée

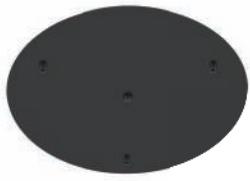

3L



9L

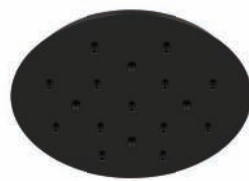

13L

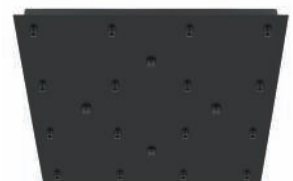

16L



3L



8L



10L



10L

2 Choose your pendant style Choisissez vos luminaires



CORETTO-P



SARABIA-P



SARABIA



SARABIA 1



MAREPERLA



SAFI



PRIDDY 2



PETTO



SABINAR



REALE



CORETTO



CERATELLA



TORTORETO



VILLORA



CORTADERAS



CANALELLO



BRIDPORT-P



TABANERA



GILWELL



BENDALL



BELESER



ESTANYS



PRIORAT



PONZANO



MURMILLO



MONTEY



PINTO



DIAMOND



RIVATO



TROY 3



RONDO



NEWTOWN



TARBES



CARLTON



ROCCAMENA



CARLTON 3



BARNSTAPLE



BORDESLEY

3 Ready, set, design! À vos marques, prêt, décorer!



P.8



P.16



P.10



P.14



P.6



P.18

4 Complete the look with our LED lamps! Compléter le look avec nos lampes DEL!



This product must be installed in accordance with the applicable installation code by a person familiar with the construction and operation of the product and the hazards involved.

Suitable anchors (not included) for total assembled light fixture weight and ceiling type must be used.

Ce produit doit être installé conformément au code d'installation applicable par une personne familiarisée avec la construction et le fonctionnement du produit et les risques encourus.

Utiliser des ancrages (non-inclus) spécialement conçus pour les matériaux de votre plafond ainsi que suffisamment solide pour soutenir adéquatement le poids total du luminaire assemblé.

204101A 3L CANOPY

Finish / Fini: Black / Noir

Suitable for E26, GU10, G9 and E12 electrical sockets with SVT or SVT-B (rayon SVT) wires.
Not compatible with LED integrated pendants.

Convient à E26, GU10, G9 et E12 avec fils SVT ou SVT-B (SVT de rayonne).
Non compatible avec des luminaires DEL intégrés.

Each pendant light must weigh less than 5 LBS (2.3 KG)
Chaque luminaire suspendu doit peser moins de 5 LBS (2.3 KG)

INCLUDED / INCLUS:

- 3 Optional Caps / 3 capuchons en option
- 3 Quick Connectors / 3 connecteurs rapides
- 3 SVT Strain Reliefs / 3 serre-fils SVT

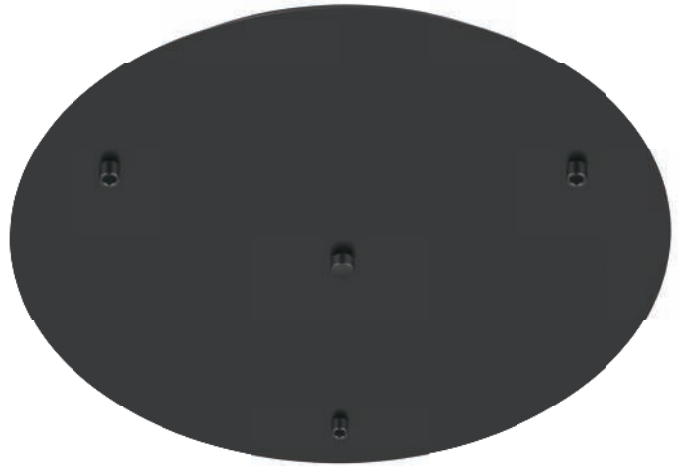

DESIGN:
DESIGN:

TOP VIEW & DIMENSIONS:
VUE DU DESSUS ET DIMENSIONS:

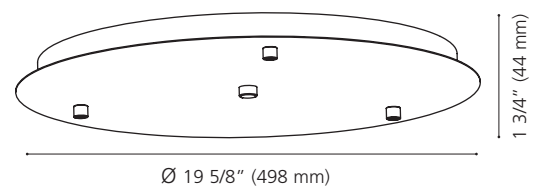
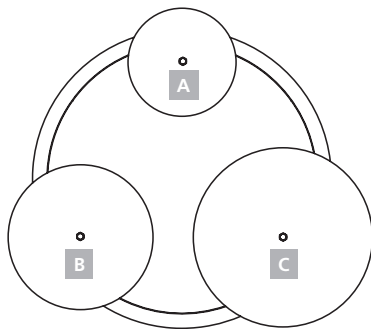
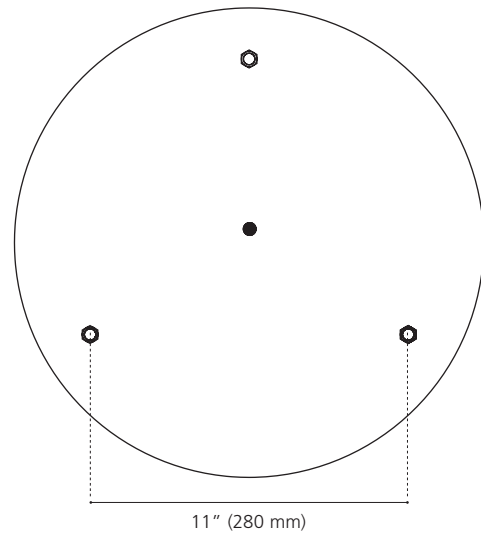
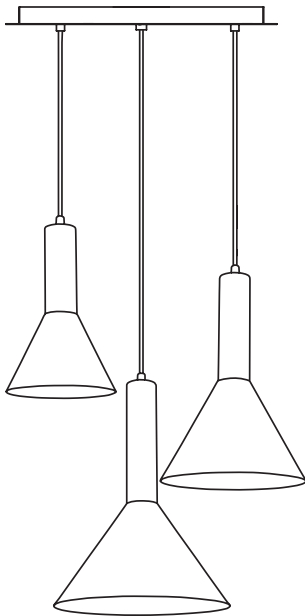



**PENDANTS DISPLAYED:
LUMINAIRES EN EXPOSITION:**

- A - 62985A / CANALELLO
- B - 62992A / CANALELLO
- C - 62998A / CANALELLO

204102A 9L CANOPY

Finish / Fini: Black / Noir

Suitable for E26, GU10, G9 and E12 electrical sockets with SVT or SVT-B (rayon SVT) wires.
Not compatible with LED integrated pendants.

Convient à E26, GU10, G9 et E12 avec fils SVT ou SVT-B (SVT de rayonne).
Non compatible avec des luminaires DEL intégrés.

Each pendant light must weigh less than 5 LBS (2.3 KG)
Chaque luminaire suspendu doit peser moins de 5 LBS (2.3 KG)

INCLUDED / INCLUS:

- 9 Optional Caps / 9 capuchons en option
- 3 Quick Connectors / 3 connecteurs rapides
- 9 SVT Strain Reliefs / 9 serre-fils SVT

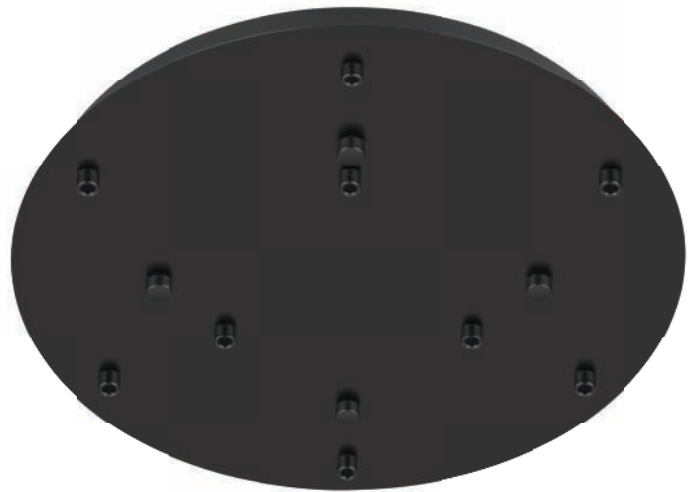

**DESIGN:
DESIGN:**

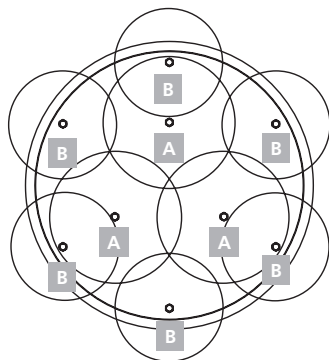
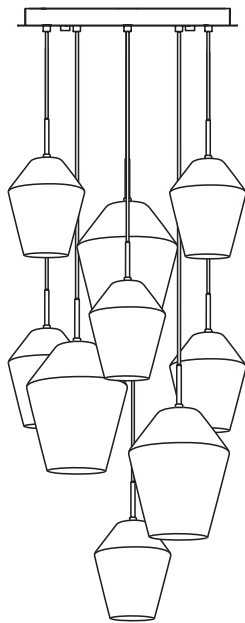

**TOP VIEW & DIMENSIONS:
VUE DU DESSUS ET DIMENSIONS:**

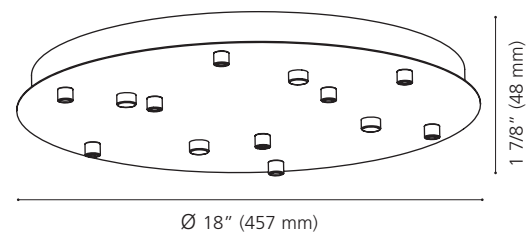
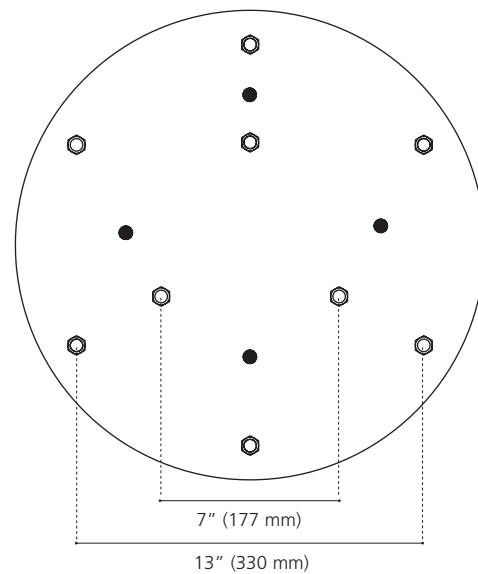



A

B

**PENDANTS DISPLAYED:
LUMINAIRES EN EXPOSITION:**

**A - 202357A / MURMILLO
B - 96773A / MURMILLO**

204103A 13L CANOPY

Finish / Fini: Black / Noir

Suitable for E26, GU10, G9 and E12 electrical sockets with SVT or SVT-B (rayon SVT) wires.
Not compatible with LED integrated pendants.

Convient à E26, GU10, G9 et E12 avec fils SVT ou SVT-B (SVT de rayonne).
Non compatible avec des luminaires DEL intégrés.

Each pendant light must weigh less than 5 LBS (2.3 KG)
Chaque luminaire suspendu doit peser moins de 5 LBS (2.3 KG)

INCLUDED / INCLUS:

- 13 Optional Caps / 13 capuchons en option
- 3 Quick Connectors / 3 connecteurs rapides
- 13 SVT Strain Reliefs / 13 serre-fils SVT

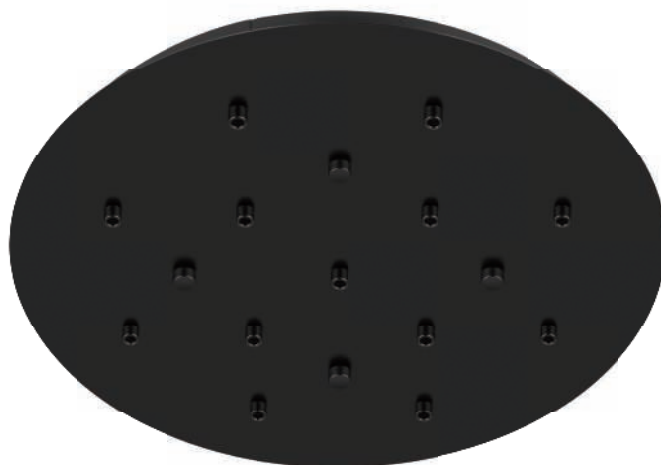

**DESIGN:
DESIGN:**

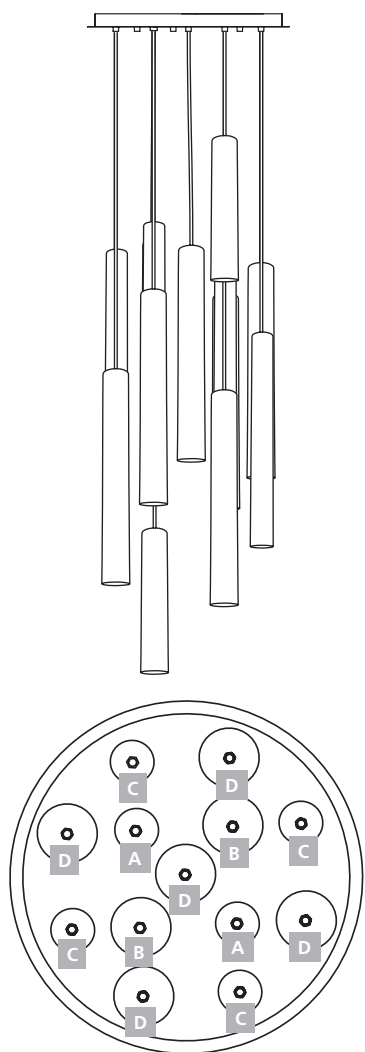

**TOP VIEW & DIMENSIONS:
VUE DU DESSUS ET DIMENSIONS:**

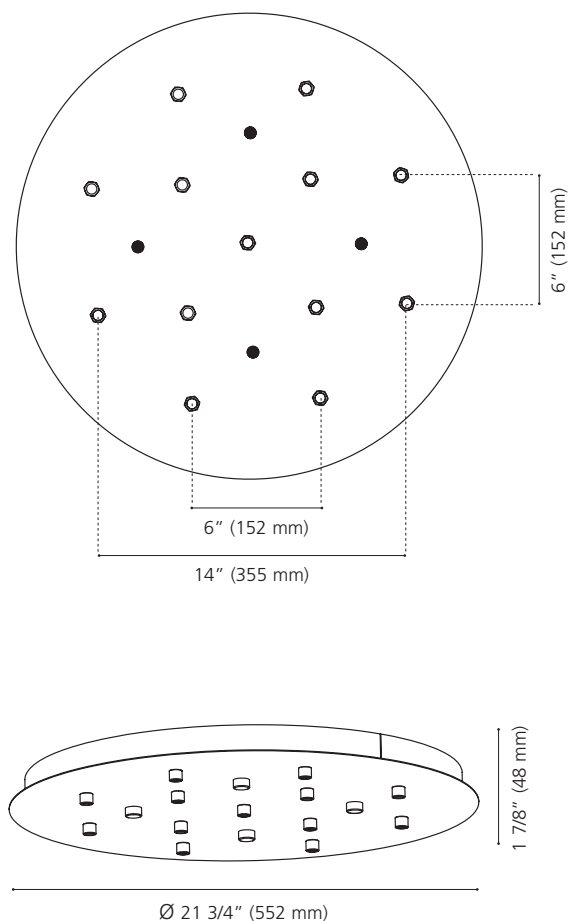



**PENDANTS DISPLAYED:
LUMINAIRES EN EXPOSITION:**

- A - 62547A / TORTORETO
- B - 62548A / TORTORETO
- C - 62557A / TORTORETO
- D - 62558A / TORTORETO

204104A 3L CANOPY

Finish / Fini: Black / Noir

Suitable for E26, GU10, G9 and E12 electrical sockets with SVT or SVT-B (rayon SVT) wires.
Not compatible with LED integrated pendants.

Convient à E26, GU10, G9 et E12 avec fils SVT ou SVT-B (SVT de rayonne).
Non compatible avec des luminaires DEL intégrés.

Each pendant light must weigh less than 5 LBS (2.3 KG)
Chaque luminaire suspendu doit peser moins de 5 LBS (2.3 KG)

INCLUDED / INCLUS:

- 3 Optional Caps / 3 capuchons en option
- 3 Quick Connectors / 3 connecteurs rapides
- 3 SVT Strain Reliefs / 3 serre-fils SVT

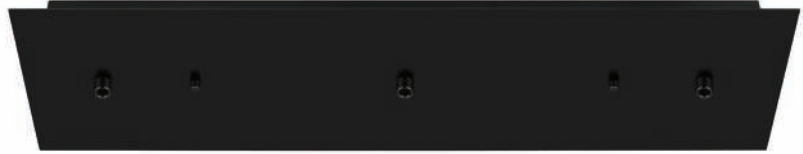

**DESIGN:
DESIGN:**

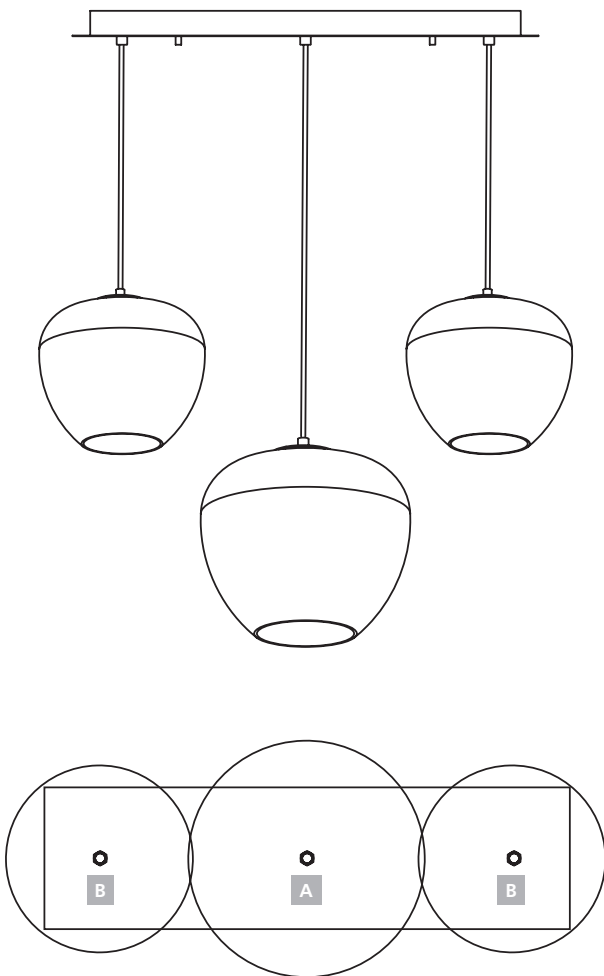

**TOP VIEW & DIMENSIONS:
VUE DU DESSUS ET DIMENSIONS:**

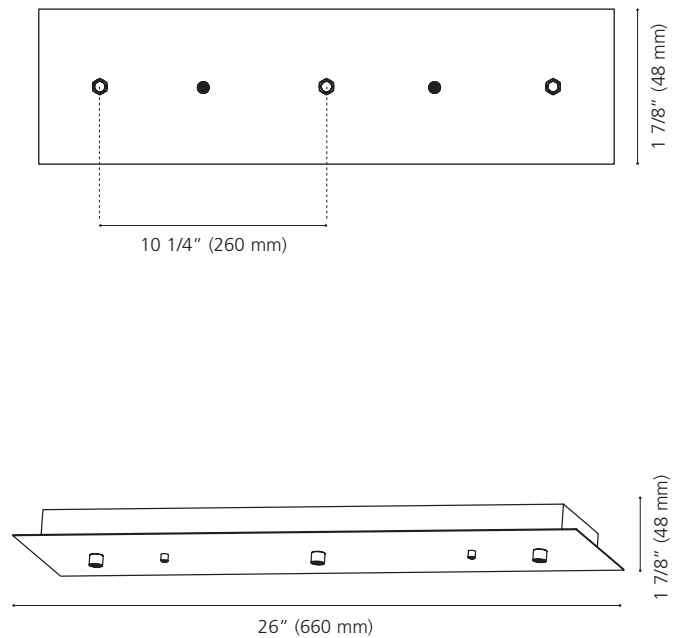



**PENDANTS DISPLAYED:
LUMINAIRES EN EXPOSITION:**

**A - 39657A / PRIORAT
B - 39656A / PRIORAT**

204105A 8L CANOPY

Finish / Fini: Black / Noir

Suitable for E26, GU10, G9 and E12 electrical sockets with SVT or SVT-B (rayon SVT) wires.
Not compatible with LED integrated pendants.

Convient à E26, GU10, G9 et E12 avec fils SVT ou SVT-B (SVT de rayon).
Non compatible avec des luminaires DEL intégrés.

Each pendant light must weigh less than 5 LBS (2.3 KG)
Chaque luminaire suspendu doit peser moins de 5 LBS (2.3 KG)

INCLUDED / INCLUS:

- 8 Optional Caps / 8 capuchons en option
- 3 Quick Connectors / 3 connecteurs rapides
- 8 SVT Strain Reliefs / 8 serre-fils SVT



**DESIGN:
DESIGN:**

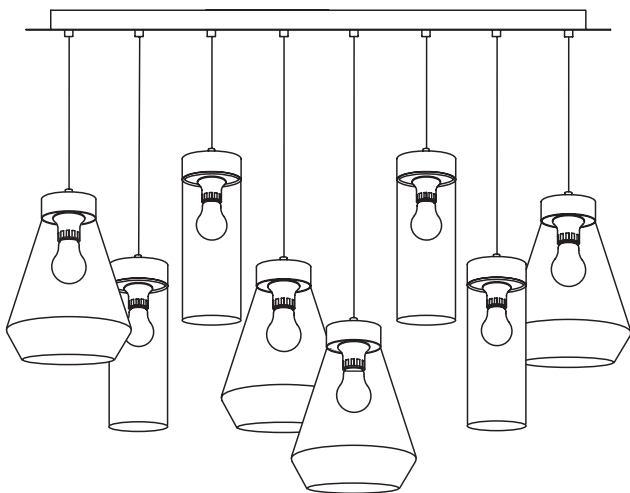

**TOP VIEW & DIMENSIONS:
VUE DU DESSUS ET DIMENSIONS:**

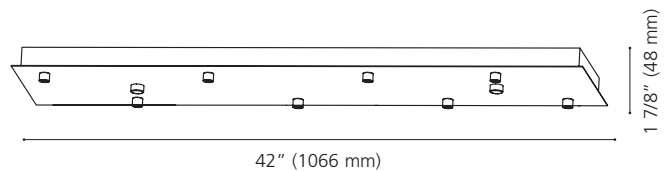
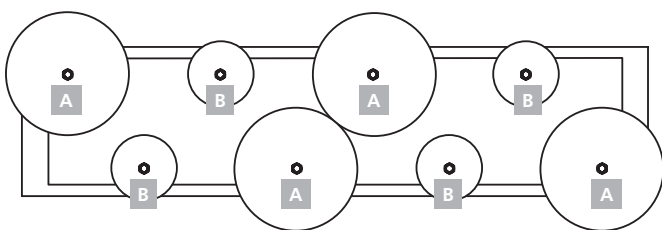
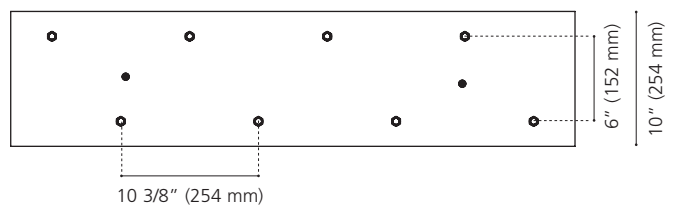



A

B

**PENDANTS DISPLAYED:
LUMINAIRES EN EXPOSITION:**

**A - 202125A / MONTEY
B - 202127A / MONTEY**

204106A 10L CANOPY

Finish / Fini: Black / Noir

Suitable for E26, GU10, G9 and E12 electrical sockets with SVT or SVT-B (rayon SVT) wires.
Not compatible with LED integrated pendants.

Convient à E26, GU10, G9 et E12 avec fils SVT ou SVT-B (SVT de rayonne).
Non compatible avec des luminaires DEL intégrés.

Each pendant light must weigh less than 5 LBS (2.3 KG)
Chaque luminaire suspendu doit peser moins de 5 LBS (2.3 KG)

INCLUDED / INCLUS:

- 10 Optional Caps / 10 capuchons en option
- 3 Quick Connectors / 3 connecteurs rapides
- 10 SVT Strain Reliefs / 10 serre-fils SVT



DESIGN:
DESIGN:

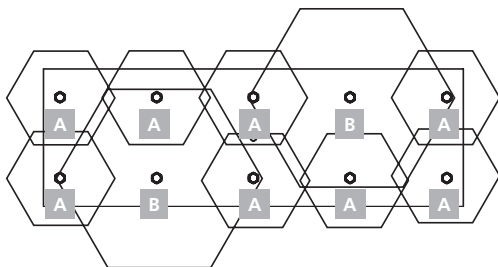
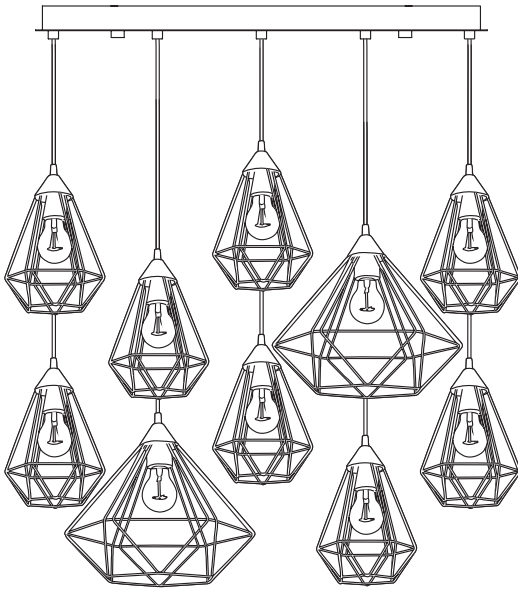

TOP VIEW & DIMENSIONS:
VUE DU DESSUS ET DIMENSIONS:

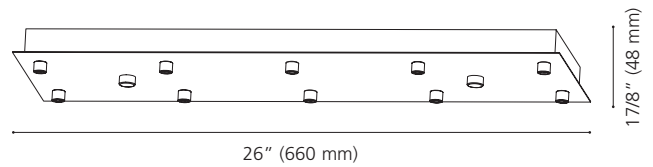
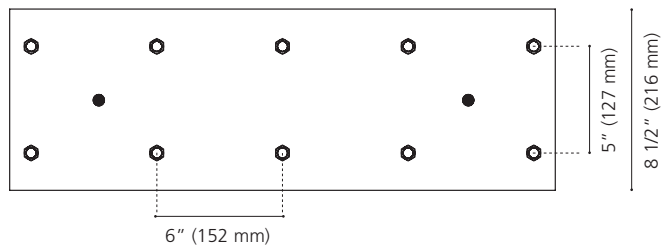



A

B



**PENDANTS DISPLAYED:
LUMINAIRES EN EXPOSITION:**

A - 94187A / TARBES
B - 94188A / TARBES

204107A 10L CANOPY

Finish / Fini: Black / Noir

Suitable for E26, GU10, G9 and E12 electrical sockets with SVT or SVT-B (rayon SVT) wires.
Not compatible with LED integrated pendants.

Convient à E26, GU10, G9 et E12 avec fils SVT ou SVT-B (SVT de rayon).
Non compatible avec des luminaires DEL intégrés.

Each pendant light must weigh less than 5 LBS (2.3 KG)

Chaque luminaire suspendu doit peser moins de 5 LBS (2.3 KG)

INCLUDED / INCLUS:

- 10 Optional Caps / 10 capuchons en option
- 3 Quick Connectors / 3 connecteurs rapides
- 10 SVT Strain Reliefs / 10 serre-fils SVT



**DESIGN:
DESIGN:**

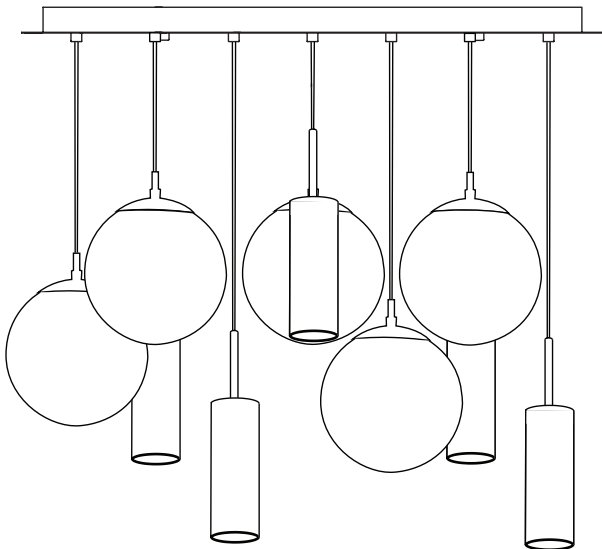

**TOP VIEW & DIMENSIONS:
VUE DU DESSUS ET DIMENSIONS:**

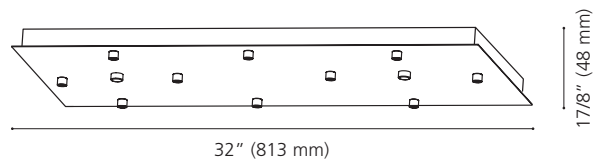
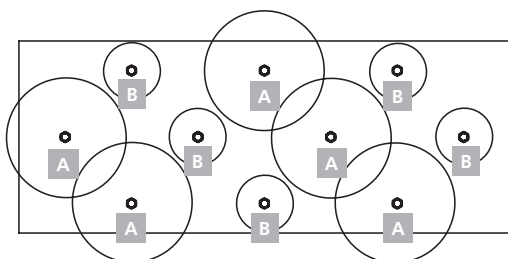
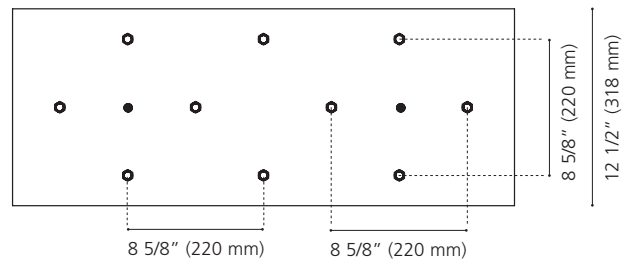



A

B

**PENDANTS DISPLAYED:
LUMINAIRES EN EXPOSITION:**

A - 85261A / RONDO
B - 85977A / TROY 3

204108A 16L CANOPY

Finish / Fini: Black / Noir

Suitable for E26, GU10, G9 and E12 electrical sockets with SVT or SVT-B (rayon SVT) wires.
Not compatible with LED integrated pendants.

Convient à E26, GU10, G9 et E12 avec fils SVT ou SVT-B (SVT de rayonne).
Non compatible avec des luminaires DEL intégrés.

Each pendant light must weigh less than 5 LBS (2.3 KG)
Chaque luminaire suspendu doit peser moins de 5 LBS (2.3 KG)

INCLUDED / INCLUS:

- 16 Optional Caps / 16 capuchons en option
- 3 Quick Connectors / 3 connecteurs rapides
- 16 SVT Strain Reliefs / 16 serre-fils SVT

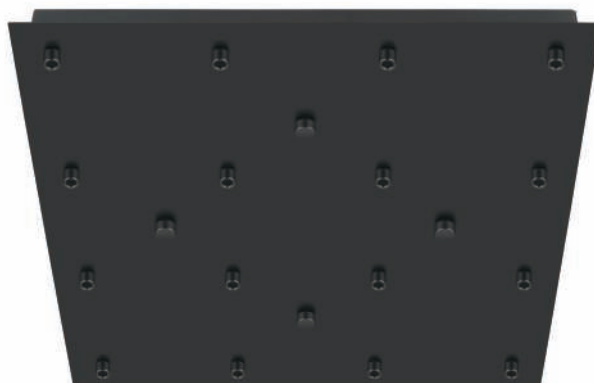

DESIGN:
DESIGN:

TOP VIEW & DIMENSIONS:
VUE DU DESSUS ET DIMENSIONS:

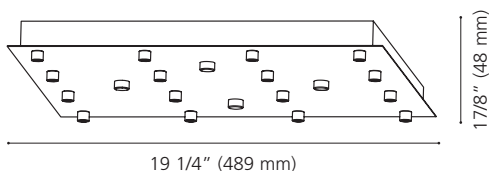
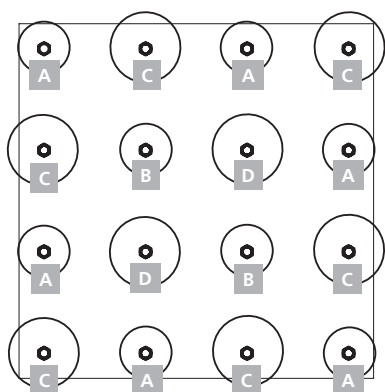
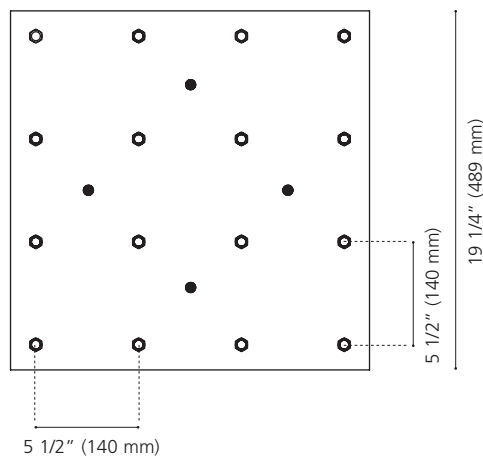
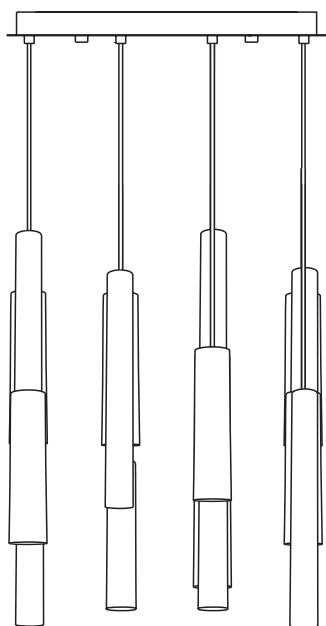



**PENDANTS DISPLAYED:
LUMINAIRES EN EXPOSITION:**

- A - 62547A / TORTORETO
- B - 62548A / TORTORETO
- C - 62557A / TORTORETO
- D - 62558A / TORTORETO



EGLO CANADA INC.

20700 Route Transcanadienne
Baie-D'Urfé, Québec H9X 4B7
Tél (514) 457 5483 / 1 (866) 492 EGLO (3456)
Fax (514) 457 5487 / 1 (866) 964 EGLO (3456)
info-canada@eglo.com / www.eglo.ca